

Acoustic insulation

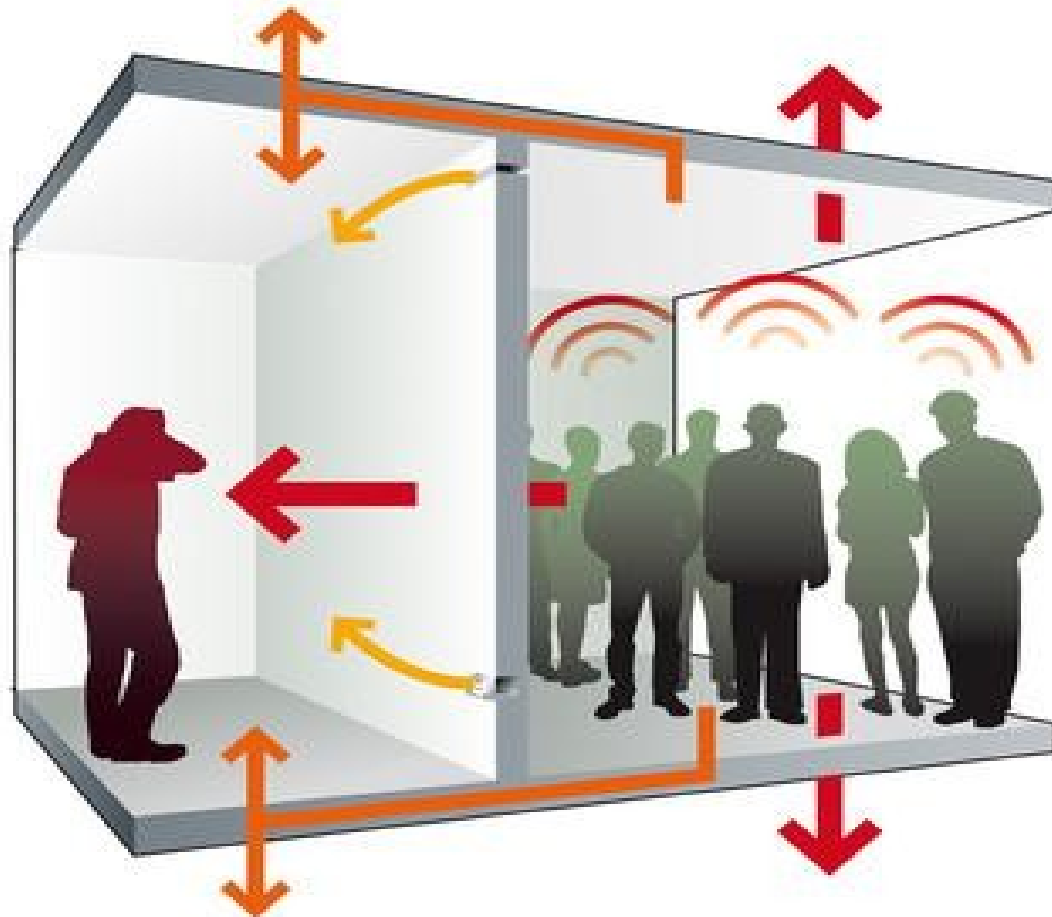

- Introduction
- Normalized sound insulation
- Sound reduction index of a wall
- Sound transmission coefficient of a wall
- Mass law and frequency effect

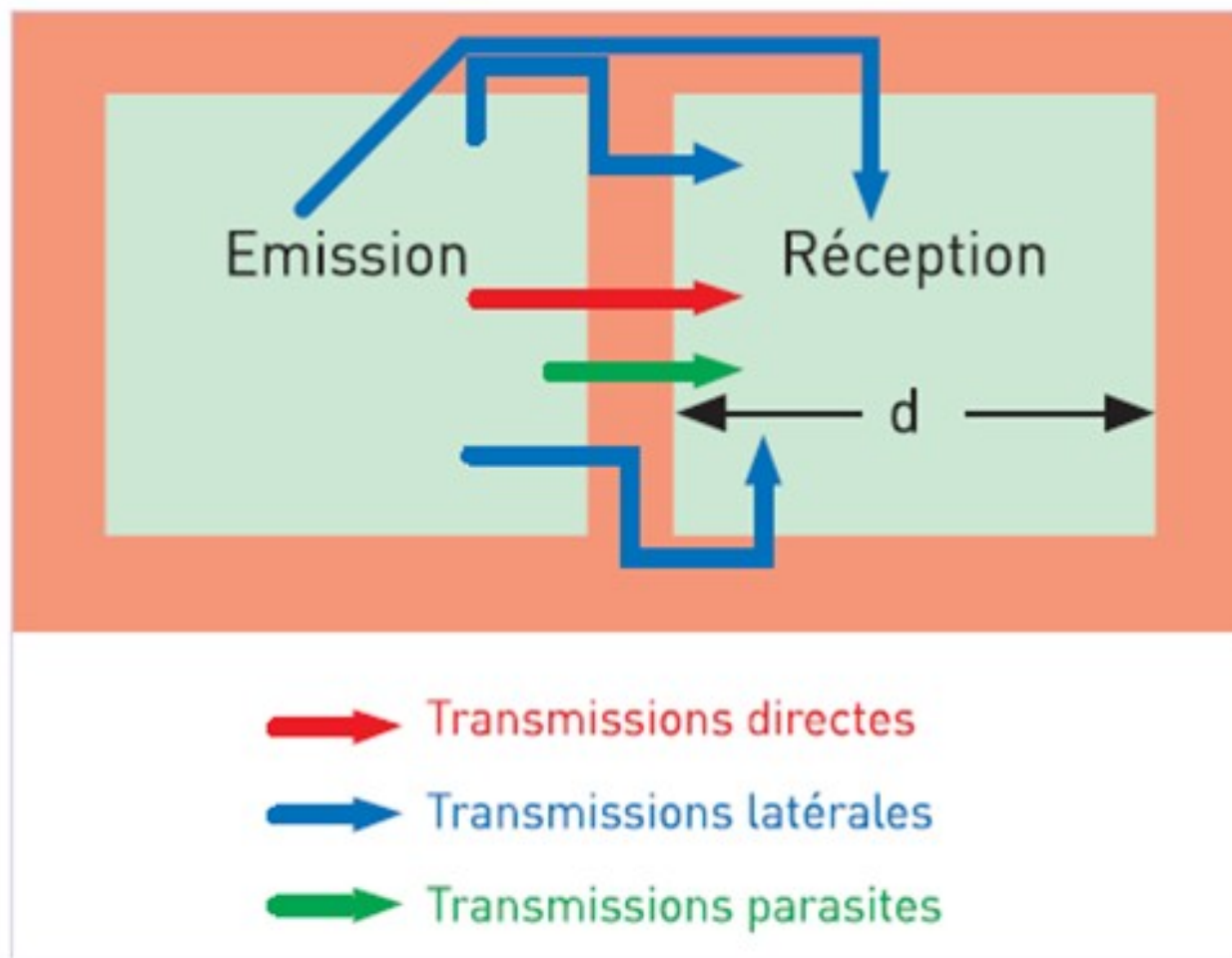

Normalized sound insulation

1 : Raw sound insulation D_b

It is the difference between the noise level L_1 in the source room and the level L_2 in the receiving room:

$$D_b = L_1 - L_2 \text{ (dB)}$$



2 : Normalized or standardized sound insulation

Normalized sound insulation is the raw sound insulation corrected according to the measured reverberation time T_r in the receiving room and a reference reverberation time T_0 :

Some values of T_0 :

- Residential buildings, healthcare facilities, hotels, and educational buildings:

$T_0 = 0.5 \text{ s}$

- Sports halls with a volume greater than 512 m^3 :

$T_0 = 0.14 V$ (V : room volume)

$$D_n = D_b + 10 \log \frac{T_r}{T_0} \text{ (dB)}$$

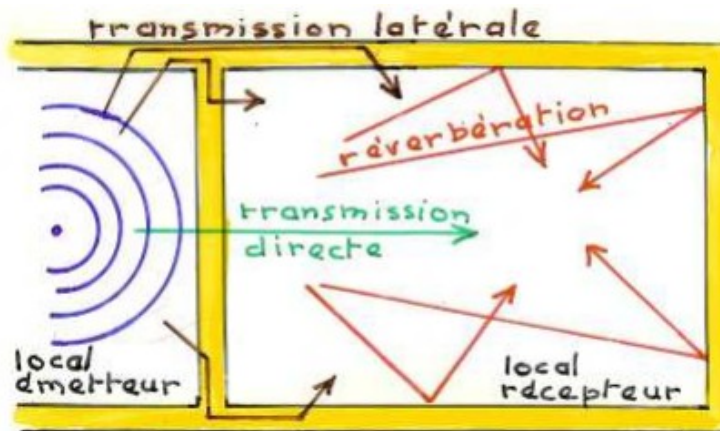

Pour les bâtiments d'habitation les valeurs réglementaires sont les suivantes

Bruits aériens intérieurs (Article 2)	Bruits de chocs (Article 4)	Bruits d'équipement (Articles 5 et 6)	Bruits aériens extérieurs (Articles 5 et 6)
Entre 2 pièces principales $D_{nT,A} \geq 53 \text{ dB}$	$L'_{nT,w} \leq 58 \text{ dB}$	En pièce principale $L_{nAT} \leq 30 \text{ dB(A)}$	$D_{nAT} \geq 30 \text{ dB}$

- $D_{nT,A}$: Weighted (A) standardized sound insulation for airborne noise, expressed in dB.
- D_{nAT} : Weighted (A) normalized sound insulation for airborne noise, expressed in dB(A).
- $L'_{nT,w}$: Weighted "W" standardized impact sound pressure level, expressed in dB.
- L_{nAT} : Weighted impact sound pressure level, standardized, expressed in dB(A).

The insulating performance of a wall

1 : Sound transmission coefficient of a wall (τ)

It is the ratio between the transmitted acoustic power and the incident acoustic power on the wall.

$$\tau = \frac{W_t}{W_i}$$

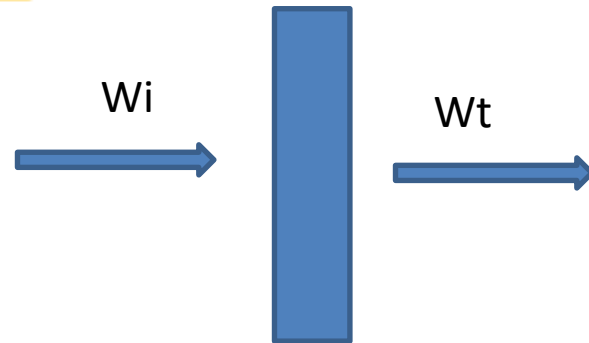

2- Sound reduction index of wall (R)

The insulating capacity of a wall is expressed using a sound reduction index denoted R, determined by the following relation:

$$R = L_{wi} - L_{wt}$$

↓ ↓ ↓

dB dB dB

dB(A) dB(A) dB(A)

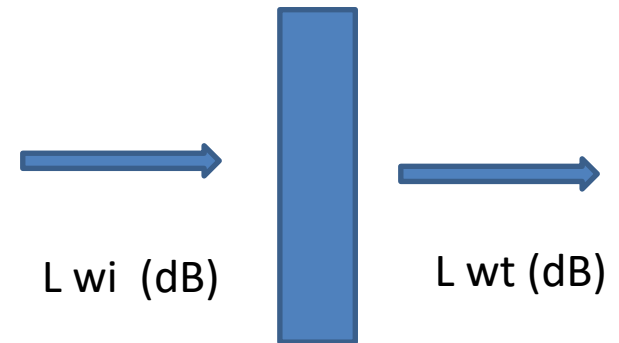

3- Relationship between the sound reduction index R and the transmission coefficient τ

$$\tau = 10^{(-R/10)}$$

$$R = 10 \log \frac{1}{\tau} \text{ (dB)}$$

The insulating quality of a wall

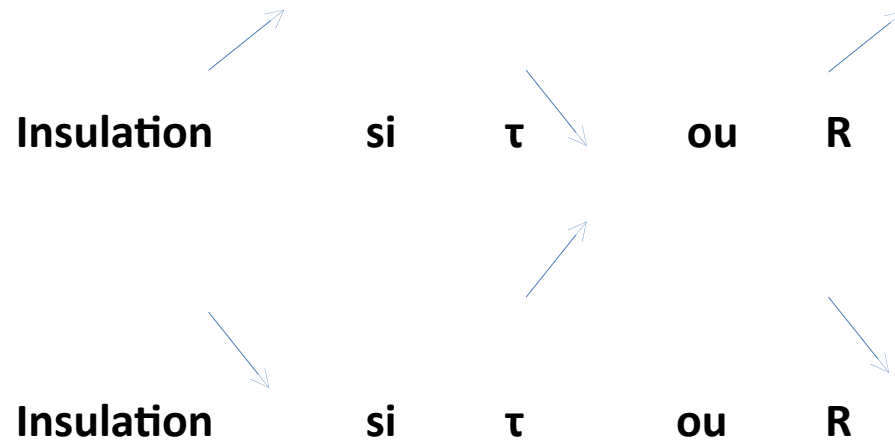

Example

Epaisseur de la paroi (cm)	10	12	14	16	18
Masse de la paroi (Kg/m ²)	250	300	350	400	450
R (dB)	48	52	55	57	58

Calculation of the transmission coefficient of a wall τ

- Case of multiple walls

a) Walls in series

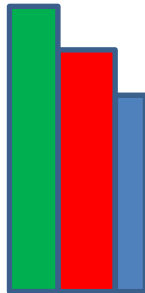

1 2 3

$$\tau_{\text{total}} = \tau_1 \times \tau_2 \times \tau_3$$

b) Walls in parallel

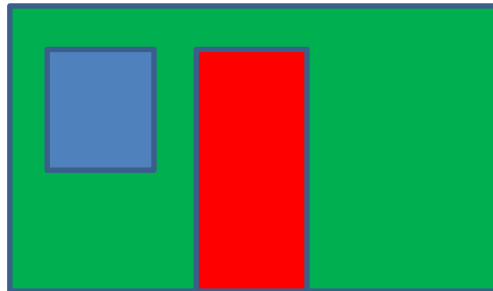

$$\tau_{\text{total}} = \frac{\tau_1 \times S_1 + \tau_2 \times S_2 + \tau_3 \times S_3}{S_1 + S_2 + S_3}$$

Relationship between the sound reduction index R and the apparent sound insulation D_b

$$A_2 = \sum_{\alpha=1}^n \alpha_i \cdot S_i$$

- A_2 : The equivalent absorption area of room 2
- S_p : The surface area of the partition wall between the two rooms (m^2)

$$D_b = R + 10 \log \frac{A_2}{S_p} \text{ (dB)}$$

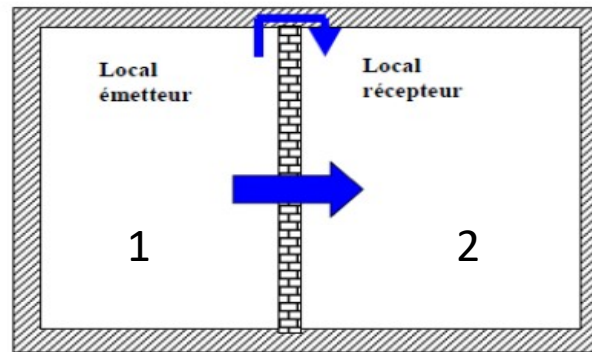

Relationship between the sound reduction index R and the normalized sound insulation D_n

- V_2 : The volume of room 2 (m^3)
- S_p : The area of the partition wall between the two rooms (m^2)

$$D_n = R + 10 \log \frac{0,32V_2}{S_p} \text{ (dB)}$$

Mass–frequency law

a) Mass law

Insulation

R (dB)

Increases with the surface mass of the material μ (kg/m²)

Si $\mu < 150$ kg/m²

$$R \text{ (dB)} = 17 \log (\mu) + 4$$

Si $\mu > 150$ kg/m²

$$R \text{ (dB)} = 40 \log (\mu) + 46$$

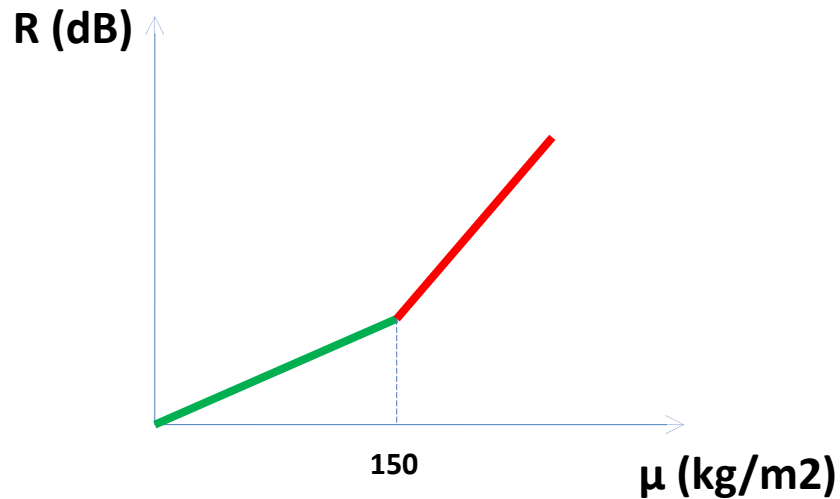

b) Frequency law

R + 4 dB **si** **f x 2**



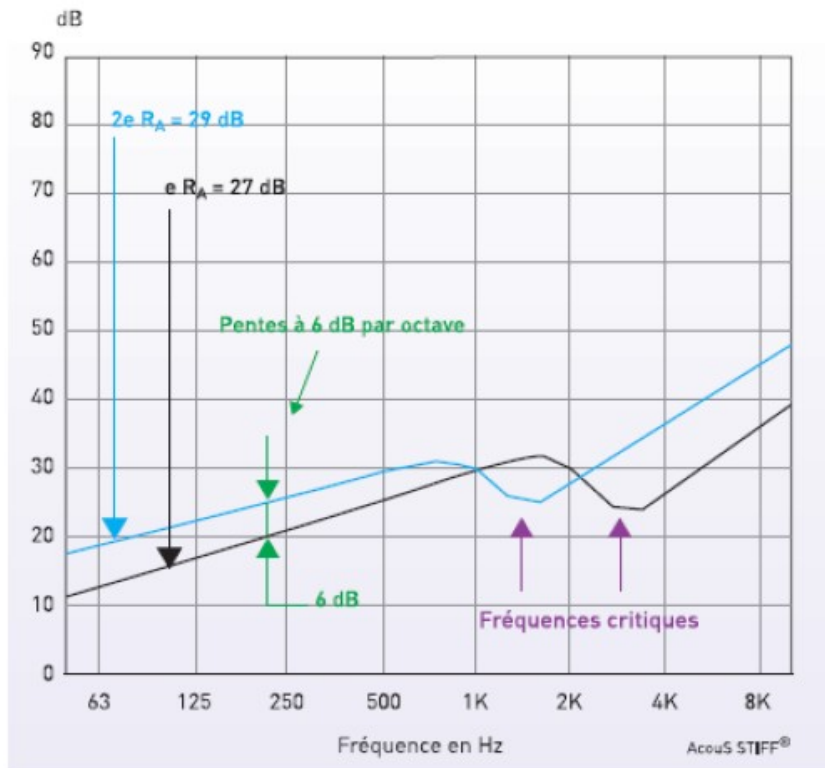

- The more rigid the wall, the lower the critical frequency
- The more flexible it is, the higher the critical frequency

Mass and frequency law

$$\tau = \frac{1}{1 + \left(\frac{\mu \cdot f}{\rho_0 \cdot c_0}\right)^2}$$

$$R = 20 \log \mu \cdot f - 47 \text{ dB}$$

avec:

μ : the surface mass of the wall in (Kg/m²)

f : the frequency of the wave in (Hz)

$\rho_0 \cdot c_0$: the acoustic impedance of air in (Kg/m²·s)

Example 1

a) - Calculate the sound reduction index R of the walls whose transmission coefficients τ are respectively: 0.1; 0.01; 0.001 ...

What can be concluded from this?

b) - On either side of a façade, the sound levels are 77 dB and 37 dB. Calculate the transmission coefficient τ of this façade.

Example 2

- a) Determine the thickness e of the glass to be used in constructing a glazed wall, knowing that it must provide a sound reduction of 28 dB at the frequency $f = 520$ Hz. (Glass density $\rho = 2500 \text{ kg}\cdot\text{m}^{-3}$)

- b) What is the acoustic attenuation of a solid concrete floor with a density $\rho = 2300 \text{ kg}\cdot\text{m}^{-3}$ and a thickness $e = 11$ cm at the frequency $f = 400$ Hz?

- c) Determine the thickness of concrete if the attenuation is 51 dB.